

ADH160H1ERG/1UH160P1ERG

DUCTED INDOOR UNIT - HIGH STATIC - SINGLE PHASE



ADH160H1ERG



1UH160P1ERG



ADH160H1ERG DUCTED



7.1kW



YR-E17
Included

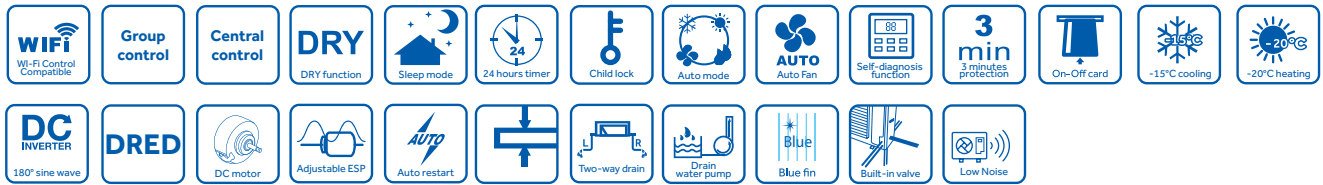

Model		Indoor unit	ADH160H1ERG	
		Outdoor unit	1UH160P1ERG	
Rated performance data	Capacity	Cooling	kW Nom (min-max) 15.5 (3.5-16.5)	
		Heating	kW Nom (min-max) 18.0 (6.0-20.0)	
	Rated power input	Cooling	kW Nom (min-max) 4.83 (2.0-7.2)	
		Heating	kW Nom (min-max) 5.13 (2.0-7.2)	
	EER		3.21	
COP		3.5		
Indoor Unit				
Electrical	Power supply	Ph/V/Hz	1/220-240/50	
Performance	Air flow (H/M/L)	m3/h	4000/3400/2800/2200	
		L/S	1115/945/780/615	
	External Static Pressure	pa	37-210	
	Sound power level (H/M/L)	dB(A)	51/47/44/40	
Installation	External dimensions (WxDxH)	mm	1350/490/425	
	Shipping dimensions (WxDxH)	mm	1565/724/510	
	Net/Shipping weight	kg	61/72	
	Supply air Flange	mm	306 X1046	
	Return Air Flange	mm	353 X 1164	
	Wired Controller	Standard		YR-E17
		Optional		YR-E16A (7 day time clock)
Outdoor Unit				
Electrical	Power supply	Ph/V/Hz	1/220-240/50	
Performance	Air flow (H)	m3/h	7500	
		L/S	2085	
	Sound power level	dB(A)	73	
	Sound pressure level	dB(A)	54	
Installation	External dimensions (HxWxD)	mm	1350/950/370	
	Shipping dimensions (HxWxD)	mm	1500/1090/480	
	Net/Shipping weight	kg	105/118	
	Compressor type		Twin rotary	
	Refrigerant type		R410A	
	Refrigerant liquid pipe	mm	9.52 (3/8)	
	Refrigerant gas pipe	mm	15.88 (5/8)	
	Max pipe length	m	75	
	Max height between I.U.&O.U	m	30	
	Refrigerant pre-charged	kg	3.7	
	Pre-charged line length	m	30	
	Additional gas charge	g/m	45	
Working temp.	Cooling (Min-Max)	°C	-15 to +50	
	Heating (Min-Max)	°C	-20 to +24	

DRAWINGS

INDOOR UNITS

ADH160H1ERG

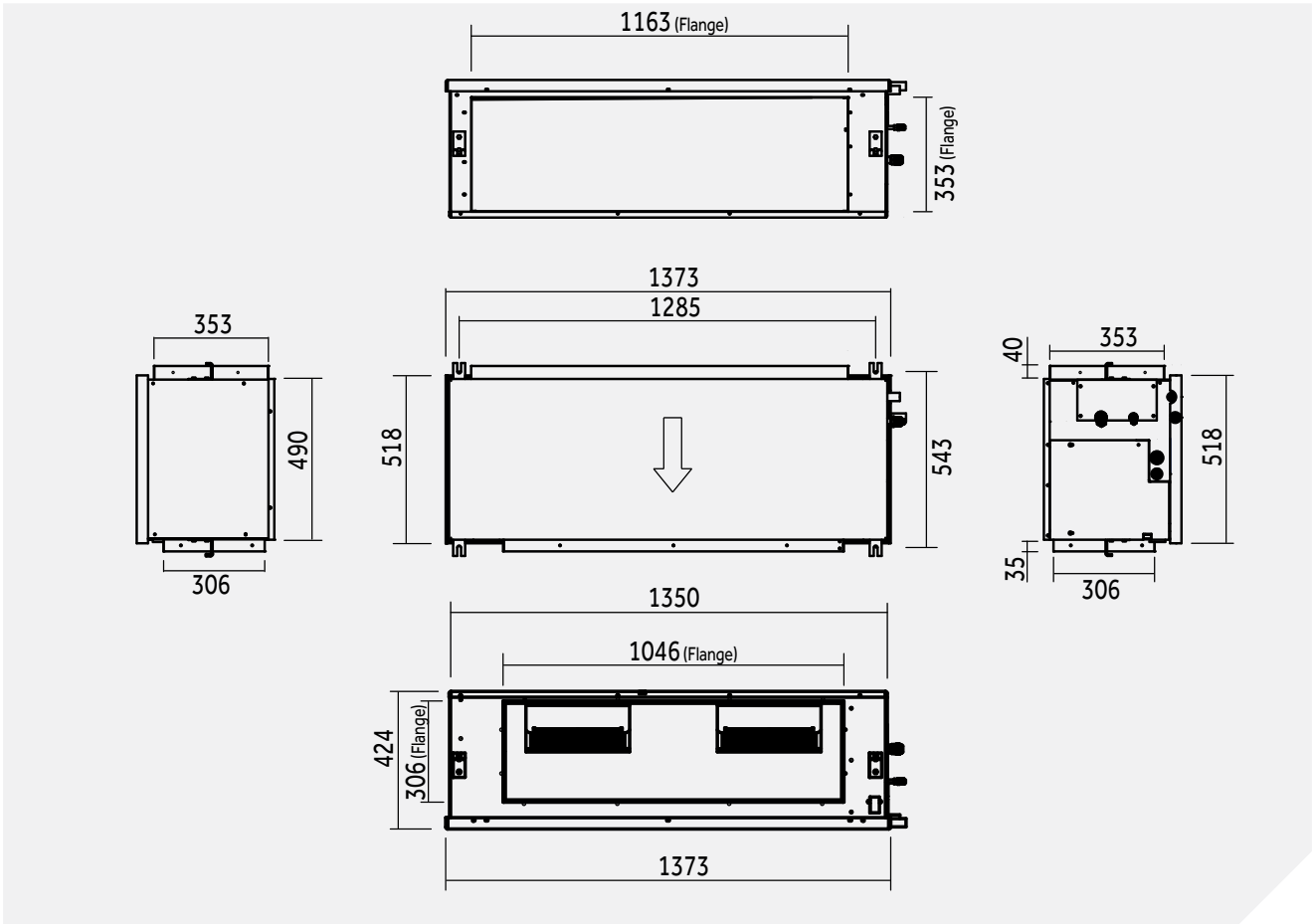

OUTDOOR UNITS

1UH160P1ERG

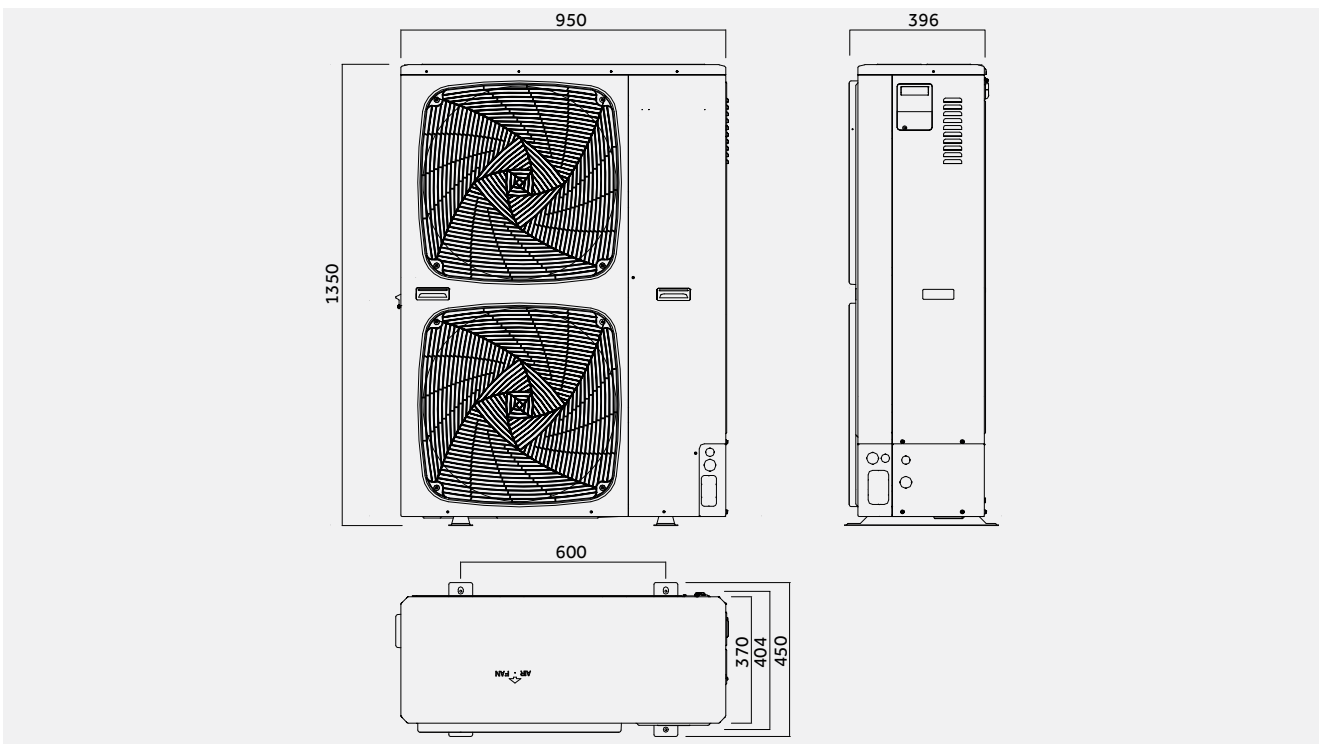



For Haier Appliances

Australia 1300 729 948 | haier.com.au

New Zealand 0800 424 372 | haier.co.nz

Haier

Important notice of Disclosure: Copyright © Fisher & Paykel Appliances 2017. All rights reserved.

The product dimensions and specifications in this brochure apply to the specific products and models described at the date of issue. Under our policy of continuous product improvement, these dimensions and specifications may change at any time. You should therefore check with your dealer or Haier's Customer Care Centre to ensure this flyer correctly describes the products currently available.

Fisher & Paykel Australia Pty Ltd, Level 1, 1 Eden Park Drive, Macquarie Park, NSW 2113.
Phone Customer Care: 1300 729 948 Email: customer.care@haier.com.au

Fisher & Paykel Appliances Ltd, 78 Springs Road, East Tamaki, Auckland 2013.
Phone Customer Care: 0800 424 372. Email: customer.care@haier.co.nz