

The Haier logo is displayed in white text on a dark grey rectangular background in the top right corner of the page.

Haier

# Refrigerator Freezer

---

HRF523XHG



## **CONTENTS**

---

SAFETY AND WARNINGS .....	4
PRODUCT OVERVIEW .....	7
CONTROL PANEL .....	8
INSTALLATION .....	9
FIRST USE .....	11
SETTING THE TEMPERATURE .....	12
SPECIAL FUNCTIONS .....	13
CARE AND CLEANING .....	14
TROUBLESHOOTING .....	16
TECHNICAL DATA .....	19
MANUFACTURER'S WARRANTY .....	20
CUSTOMER SERVICE .....	22

## SAFETY AND WARNINGS

### **⚠ WARNING!**



**This appliance contains flammable refrigerant isobutane (R600a).**

### **READ AND SAVE THIS GUIDE**

In the interest of your safety and to ensure the correct use, before installing and first using the appliance, read this user manual carefully, including its hints and warnings. To avoid unnecessary mistakes and accidents, it is important to ensure that all people using the appliance are thoroughly familiar with its operation and safety features. Save these instructions and make sure that they remain with the appliance if it is moved or sold, so that everyone using it through its life will be properly informed on appliance use and safety. For the safety of life and property keep the precautions of these user's instructions as the manufacturer is not responsible for damages caused by omission.

### **Children and vulnerable people safety**

- This appliance can be used by children aged from 8 years and above and persons with reduced physical, sensory or mental capabilities or lack of experience and knowledge if they have been given supervision or instruction concerning use of the appliance in a safe way and understand the hazards involved.
- Children should be supervised to ensure that they do not play with the appliance.
- Cleaning and user maintenance shall not be done by children unless they are aged from 8 years and above and supervised.
- Keep all packaging well away from children. There is risk of suffocation.

### **General safety**

- **⚠ WARNING!** Keep ventilation openings, in the appliance enclosure or in the built-in structure, clear of obstruction.
- **⚠ WARNING!** Do not use mechanical devices or other means to accelerate the defrosting process, other than those recommended by the manufacturer.
- **⚠ WARNING!** Do not damage the refrigerant circuit.
- **⚠ WARNING!** When positioning the appliance, ensure the supply cord is not trapped or damaged.
- **⚠ WARNING!** Do not use other electrical appliances (such as ice cream makers) inside of refrigerating appliances, unless they are approved for this purpose by the manufacture.
- **⚠ WARNING!** Do not touch the light bulb if it has been on for a long period of time because it could be very hot.\*
- Do not store explosive substances such as aerosol cans with a flammable propellant in this appliance.
- The refrigerant isobutane (R600a) is contained within the refrigerant circuit of the appliance, a natural gas with a high level of environmental compatibility, which is nevertheless flammable.
- During transportation and installation of the appliance, be certain that none of the components of the refrigerant circuit become damaged.
- Avoid open flames and sources of ignition.
- Thoroughly ventilate the room in which the appliance is situated
- It is dangerous to alter the specifications or modify this product in any way. Any damage to the cord

\*if there is a light in the compartment

## SAFETY AND WARNINGS

---

- This appliance is intended to be used in household and similar applications such as staff kitchen areas in shops, offices and other working environments; farm houses and by clients in hotels, motels and other residential type environments; catering and similar non-retail applications.
- ⚠️ **WARNING!** Any electrical components (plug, power cord, compressor and etc.) must be replaced by a certified service agent or qualified service personnel.
- ⚠️ **WARNING!** The light bulb supplied with this appliance is a “special use light bulb” usable only with the appliance supplied. This “special use light bulb” is not usable for domestic lighting.
- It is hazardous for anyone other than an Authorized Service Person to service this appliance. In Queensland – the authorized Service Person MUST hold a Gas Work Authorization for hydrocarbon refrigerants, to carry out Servicing or repairs which involve the removal of covers.
- Power cord must not be lengthened.
- ⚠️ **WARNING!** Make sure that the power plug is not squashed or damaged by the back of the appliance. A squashed or damaged power plug may overheat and cause a fire.
- Make sure that you can reach the mains plug of the appliance.
- Do not pull the mains cable.
- If the power plug socket is loose, do not insert the power plug. There is a risk of electric shock or fire.
- You must not operate the appliance without the light bulb.
- This appliance is heavy. Care should be taken when moving it.
- Do not remove nor touch items from the Cool Zone if your hands are damp/wet, as this could cause skin abrasions or frost/freezer burns.
- ⚠️ **WARNING!** Do not locate multiple portable socket-outlets or portable power supplies at the rear of the appliance
- Avoid prolonged exposure of the appliance to direct sunlight.

### Daily use

- Do not put any hot items on the plastic parts in the appliance.
- Do not place food products directly against the rear wall.
- Frozen food must not be re-frozen once it has been thawed out.
- Store pre-packed frozen food in accordance with the frozen food manufacture's instructions.
- Appliance's manufactures storage recommendations should be strictly adhered to. Refer to relevant instructions.
- Do not place carbonated or fizzy drinks in the Cool Zone as it creates pressure on the container, which may cause it to explode, resulting in damage to the appliance.
- Ice lollies can cause frost burns if consumed straight from the appliance.
- The supply cord is damaged it must be replaced by the manufacturer, service agent or similarly qualified persons in order to avoid a hazard.
- Do not replace the LED light bulb yourself, it must only be replaced by either the manufacturer or the authorised service agent.

### Care and cleaning

- Before maintenance, switch off the appliance and disconnect the mains plug from the mains socket.
- Do not clean the appliance with metal objects.
- Do not use sharp objects to remove frost from the appliance. Use a plastic scraper.
- Regularly examine the drain in the refrigerator for defrosted water. If necessary, clean the drain. If the drain is blocked, water will collect in the bottom of the appliance.

## SAFETY AND WARNINGS

---

### Installation(after unboxing)

**Important! For electrical connection carefully follow the instructions below.**

- Unpack the appliance and check it for damage. Do not connect the appliance if it is damaged. Report possible damage immediately to the place of purchase. In that case retain packaging.
- It is advisable to wait at least four hours before connecting the appliance to allow the oil to flow back in the compressor.
- Adequate air circulation should be around the appliance to avoid overheating. To achieve sufficient ventilation follow the instructions relevant to installation.
- Wherever possible the spacers of the product should be against a wall to avoid touching or catching warm parts (compressor, condenser) to prevent possible burn.
- The appliance must not be located close to radiators or cookers.
- Make sure that the mains plug is accessible after the installation of the appliance.



### Service

- Any electrical work required to do the servicing of the appliance should be carried out by a qualified electrician.
- This product must be serviced by an authorized Service Center, and only genuine spare parts must be used.

### Energy saving

- Do not put hot food in the appliance.
- Do not pack food close together as this prevents air circulating.
- Make sure food does not touch the back of the compartment(s).
- If electricity goes off, do not open the door(s).
- Do not open the door(s) frequently.
- Do not keep the door(s) open for too long.
- Do not set the thermostat to exceedingly cold temperatures.
- Some accessories, such as drawers, can be removed to achieve larger storage volume and lower energy consumption.

### Environment Protection

-  This appliance does not contain gasses which could damage the ozone layer, in either its refrigerant circuit or insulation materials. The appliance shall not be discarded together with the urban refuse and rubbish. The insulation foam contains flammable gases: the appliance shall be disposed according to your local authority's appliance disposal regulation. Avoid damaging the cooling unit, especially the heat exchanger. The materials used on this appliance marked by the  symbol are recyclable.
-  The symbol on the product or on its packaging indicates that this product may not be treated as household waste. Instead it should be taken to the appropriate collection point for the recycling of electrical and electronic equipment. By ensuring this product is disposed of correctly, you will help prevent potential negative consequences for the environment and human health, which could otherwise be caused by inappropriate waste handling of this product. For more detailed information about recycling of this product, please contact your local council, your household waste disposal service or the shop where you purchased the product.

### Packaging materials

-  Materials with this symbol are recyclable. Dispose packaging in a suitable collection containers to recycle.

### Disposal of the appliance

- Disconnect the mains plug from the mains socket.
- Cut off the mains cable and discard it.

# PRODUCT OVERVIEW

## Overview

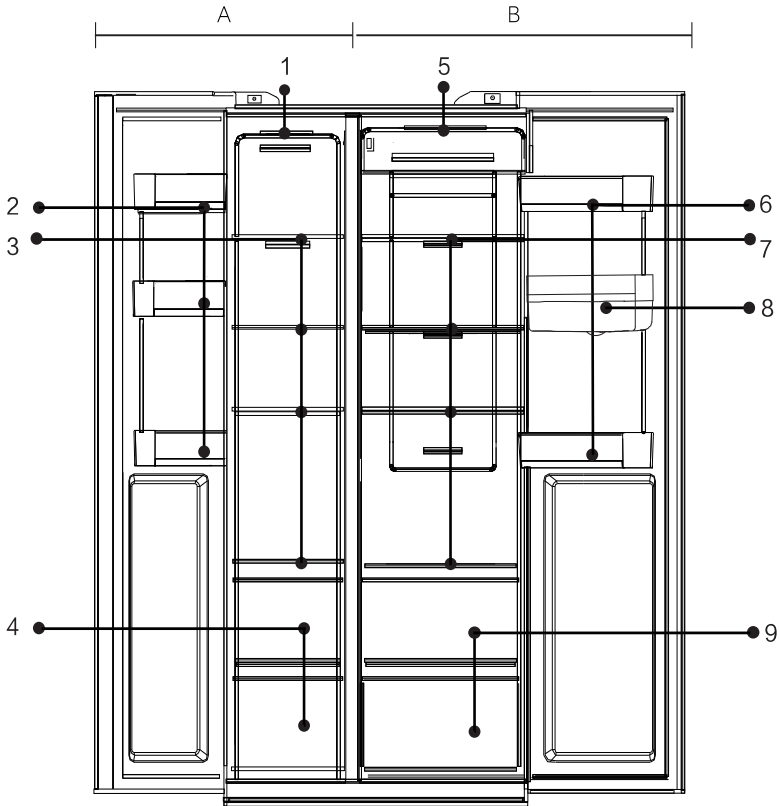

### A: Freezer Compartment

- |   |                     |
|---|---------------------|
| 1 | Ceiling lamp        |
| 2 | Door Shelves        |
| 3 | Compartment Shelves |
| 4 | Freezer Drawers     |

### B: Fridge Compartment

- |   |                         |
|---|-------------------------|
| 5 | Ceiling lamp            |
| 6 | Door rack/bottle holder |
| 7 | Fridge Shelves          |
| 8 | Water tank              |
| 9 | Fridge Box              |

## CONTROL PANEL

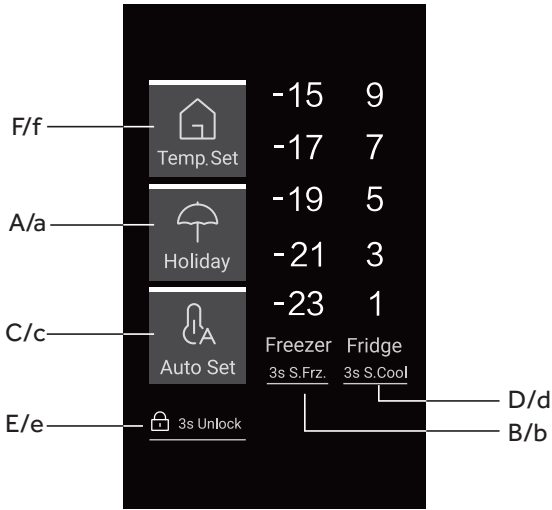

### BUTTON SELECTION:

A	Holiday Mode
B	Freezer Temperature
C	Auto Set
D	Fridge Temperature
E	Control Panel Lock
F	Temperature Set Mode

### INDICATORS:

a	Holiday Mode
b	Freezer Temperature
c	Auto Set
d	Fridge Temperature
e	Control Panel Lock
f	Temperature Set

### FUNCTIONS:

1	a	Holiday mode	After starting this scene, the icon lights up, the refrigeration setting is set to 9 °C, and the temperature of freezer can be adjusted
2	b	Freezer Temperature	Temperature set in the freezer compartment; Fully illuminated during quick freezing
3	c	Auto Set	When illuminated, the intelligent temperature setting function is turned on
4	d	Fridge Temperature	Temperature set in the fridge compartment; Fully illuminated during rapid cooling
5	e	Control Panel Lock	Press and hold the Lock icon for 3 seconds to switch between the lock and unlock states of the display panel
6	f	Temperature Set Mode	When the icon is illuminated, the fridge and freezer temperature can be adjusted

# INSTALLATION

## Unpacking

### WARNING!

- ▶ The appliance is heavy. Always handle with at least two persons.
- ▶ Keep all packaging materials out of children's reach and dispose them in an environmentally friendly manner.
- ▶ Take the appliance out of the packaging.
- ▶ Remove all packaging materials.

### Environmental conditions

The room temperature should always be between 10° C and 43° C, since it can influence the temperature inside the appliance and its energy consumption. Do not install the appliance near other heat-emitting appliances (ovens, refrigerators) without insulation.

### Space recommendation

Recommended clearance when door is opened (Fig. 1.2.)

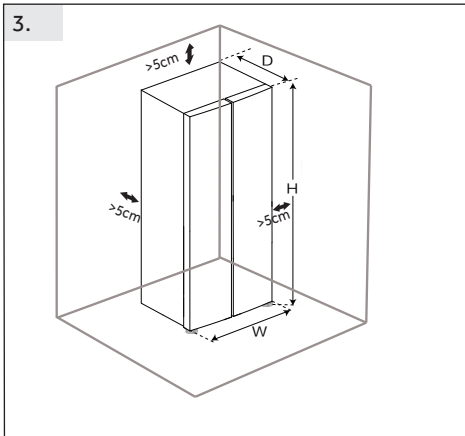
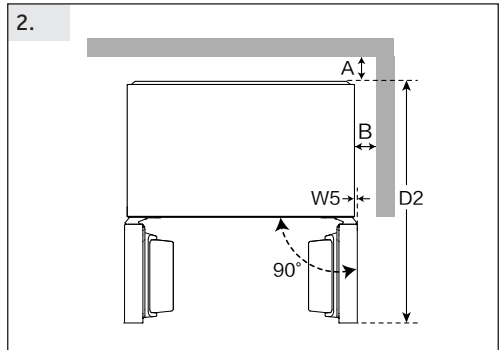
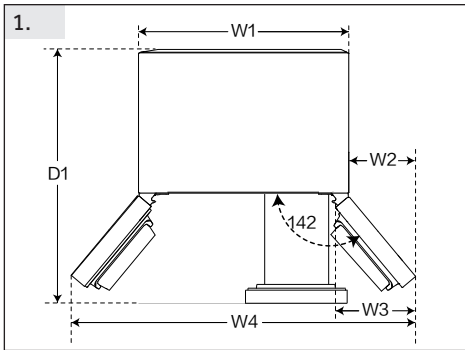

(Unit : mm)		HRF523XHG	
Width	W1		905
	W2		381
	W3		451
	W4		1579
	W5		20.5
	W		908
Depth	D1		1005
	D2		1103
	D		647
Distance to back wall	A		>50
Distance to lateral walls	B		>50
Overall Height	H		1775

# INSTALLATION

---

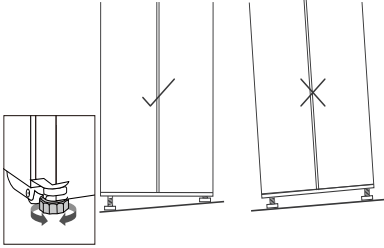

## Aligning the appliance

The appliance should be placed on a flat and solid surface.

## NOTICE

For a free standing appliance: this refrigerating appliance is not intended to be used as a built-in appliance

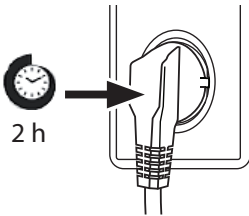

## Electrical connection

Before connecting, check:

- Power supply matches the specifications on the rating plate
- Power plug matches the power socket

## WARNING!

To avoid risks a damaged power cord must be replaced by the customer service (see warranty card).

## FIRST USE

---

Remove all packaging materials, keep them out of children's reach and dispose of them in an environmentally friendly manner.

Clean the inside and outside of the appliance with water and mild detergent. Dry well with a soft cloth. Connect product to a power supply and ensure compartments are cold before loading with food.

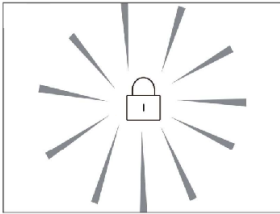

### **Lock / Unlock Control Panel**

- The control panel is automatically locked if no key is touched for 30 seconds. It will need to be unlocked to access any function aside from the water dispenser.
- While in a locked state, hold key "3s unlock" for 3 seconds to unlock the Control Panel.
- While in an unlocked state, hold key "3s unlock" for 3 seconds to lock the Control Panel. Alternatively, if no key is touched for 30 seconds, it will also automatically lock.

### **Standby Mode**

The display turns off automatically if no key is touched for 30 seconds and goes into a locked state. It will light up again if any key is touched or one of the doors is opened.

### **Door Alarm**

When a door is left open for more than 3 minutes, the door alarm will sound. The alarm will turn off

## SETTING THE TEMPERATURE

There are two ways to set the temperature of the appliance.

### Auto Set Mode

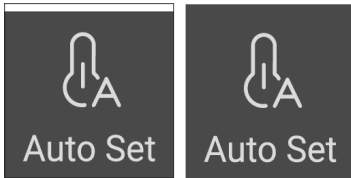

The appliance automatically adjusts the temperature setting based on the ambient temperature and temperature change in the appliance. In this mode, the temperature of the fridge and freezer cannot be adjusted manually.

To enter Auto Set Mode:

1. Unlock the control panel by holding "3s unlock" if it is locked
2. Press "Auto Set" key
3. The "Auto Set" indicator will light up when the function is activated.

Pressing the Auto Set key again or selecting any of the other functions (Holiday, Super Freeze, Super Cool) will switch off Auto Set Mode.

### NOTICE

In Auto Set mode, the temperature of the fridge and freezer cannot be adjusted manually.

### Manual adjusting mode

If you want to manually adjust the temperature of the appliance in order to store a particular food, you can set the temperature via a temperature adjusting key

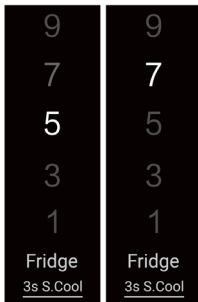

### Adjust the temperature of the fridge

1. Unlock the panel by touching key "3s.unlock" for 3 seconds if it is locked.
2. Touch key "Fridge" to select the fridge compartment. The temperature in the fridge compartment starts flashing.
3. Touch key "Fridge" repeatedly until the desired temperature is flashing. A signal will sound at each key touch.
4. The temperature decreases in sequences of 2°C from a maximum of 9°C to a minimum of 1°C. The optimum temperature in the fridge is 5°C. Colder temperatures mean unnecessary energy consumption.
5. Touch any key except "Fridge" to confirm, or the setting confirms automatically after 5 seconds. The displayed temperature stops flashing.

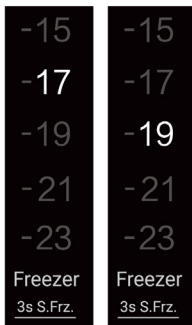

### Adjusting the freezer temperature

1. Unlock the control panel by holding "3s unlock" if it is locked.
2. Press the "Freezer" key to select the freezer compartment. The temperature of the freezer compartment will begin flashing.
3. Press the "Freezer" key repeatedly until the desired temperature is reached.
4. Press any key other than "Freezer" to confirm, or it will automatically confirm after 5 seconds and the displayed temperature will stop flashing.

**Note:** The temperature cannot be adjusted manually if any other function (Super Cool, Super Freezer, Holiday, Auto Set) is activated or display is locked.

## SPECIAL FUNCTIONS

9  
7  
5  
3  
1

Fridge  
3s S.Cool

### Super Cool Function

This function is recommended if you plan to add a large quantity of food to the fridge.

To enter Super Cool:

1. Unlock the control panel by holding "3s unlock" if it is locked
2. Hold the "3s S.Cool" key for 3 seconds
3. The fridge temperature Indicators will light up to show the function is activated.

Holding the "3s S.Cool" key again or selecting Holiday function will switch off Super Cool Mode. It will also automatically switch off after ~6 hours.

-15  
-17  
-19  
-21  
-23

Freezer  
3s S.Frz.

### Super Freeze Function

This function is recommended if you want to freeze food as quickly as possible. If you need to freeze a large amount of food, it is recommended to set the Super Freeze function 24 hours before loading the food.

To enter Super Freeze:

1. Unlock the control panel by holding "3s unlock" if it is locked
2. Hold the "3s S.Frz" key for 3 seconds
3. The freezer temperature Indicators will light up to show the function is activated.

Holding the "3s S.Frz" key again for 3s or selecting Auto Set Mode will switch off Super Freeze Mode. It will also automatically switch off after ~50 hours.

### Holiday Function

This function sets the fridge temperature to 9°C. This is intended for an empty fridge to prevent odours, not for food storage. The freezer compartment is not affected by this setting.

To enter Holiday function:

1. Unlock the control panel by holding "3s unlock" if it is locked
  2. Press the "Holiday" key
  3. The Holiday icon lights up to show Holiday function is activated
- Pressing Holiday key again switches off the function.

Warning: No food should be stored in the fridge compartment when Holiday function is activated as 9°C is unsafe for food storage.

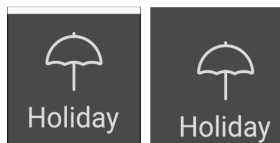

## CARE AND CLEANING

### Water dispenser

The water tank should be cleaned before first use-see "Care and Cleaning" section.

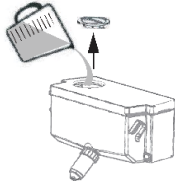

#### Filling the water tank

1. Rotate and lift the round lid and fill the water tank up with drinking water. No other liquids should be used.
2. Fill water only up to a maximum of 2.5L as there is risk of overflow when filled above this level.
3. Regularly clean the tank and replace the water.



#### Dispensing Water

1. Place glass underneath the water outlet.
2. Push the glass gently against the water dispenser paddle to dispense water.

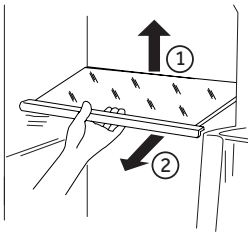

#### Adjusting Shelves

The height of the shelves can be adjusted based on your storage needs.

1. To remove the shelf, lift it up by its rear edge and then pull it out.
2. To reinstall, place it on the lugs on both sides and push it back until the shelf stays in place.

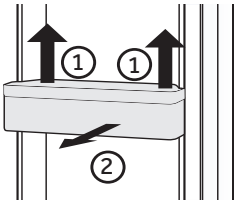

#### Removing Door Shelves

The door shelves can be removed for cleaning.

1. To remove the door shelves, hold both sides of the shelf and lift it up (1) and pull it out (2).
2. Repeat step 1 in reverse order to re-inserted.

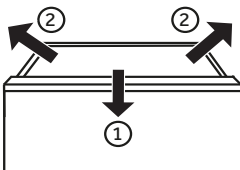

#### Removing Drawers

1. To remove the drawer, pull it out to its full extension, then lift and remove.
2. Repeat step 1 in reverse order to re-insert.

## CARE AND CLEANING

---

### WARNING!

Disconnect the appliance from the power supply before cleaning.

### Cleaning

1. Clean the appliance when only little or no food is stored.
2. The appliance should be cleaned every four weeks for good maintenance and to prevent bad stored food odors.

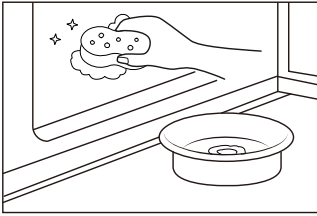

### Tips

- Use a sponge or cloth, cleaning the interior, exteriors, and gasket.
- Take care with cleaning the freezer compartment, as wet hands may freeze onto the surface.
- Do not clean the appliance with hard brushes, wire brushes, acidic or alkaline solution.
- Do not clean any parts of the appliance in a dishwasher.

### Defrosting

The defrosting of the refrigerator and the freezer compartment are done automatically, no manual operation is needed.

## TROUBLESHOOTING

### Overview

Many occurring problems could be solved by yourself without specific expertise. In case of a problem please check all shown possibilities and follow below instructions before you contact an after sales service. See CUSTOMER SERVICE.

### WARNING!

- ▶ Before maintenance, deactivate the appliance and disconnect the mains plug from the mains socket.
- ▶ Electrical equipment should be serviced only by qualified electrical experts, because improper repairs can cause considerable consequential damages.
- ▶ A damaged supply should only be replaced by the manufacturer, its service agent or similarly qualified persons in order to avoid a hazard.

PROBLEM	POSSIBLE CAUSES	WHAT TO DO
<b>The compressor does not work.</b>	Mains plug is not connected in the mains socket.	Connect the mains plug.
	The appliance is in the defrosting cycle	This is normal for an automatic defrosting
<b>The appliance runs frequently or runs for a too long period of time.</b>	The indoor or outdoor temperature is too high.	In this case, it is normal for the appliance to run longer.
	The appliance has been off power for a period of time.	Normally, it takes 8 to 12 hours for the appliance to cool down completely.
	A door of the appliance is not tightly closed.	Close the door/drawer and ensure the appliance is located on a level ground and there is no food or container jarring the door.
	The door has been opened too frequently or for too long.	Do not open the door/drawer too frequently.
	The temperature setting for the freezer compartment is too low.	Set the temperature higher until a satisfactory refrigerator temperature is obtained. It takes 24 hours for the refrigerator temperature to become stable.
	The door gasket is dirty, worn, cracked or mismatched.	Clean the door/drawer gasket or replace them by the customer service.
<b>The inside of the refrigerator is dirty and/or smells.</b>	The clearance gaps around the product are insufficient for air circulation.	Ensure recommended clearance around the appliance.
	The inside of the refrigerator needs cleaning.	Clean the inside of the refrigerator.
	Food of strong odour is stored in the refrigerator.	Wrap or seal food tightly.

## TROUBLESHOOTING

PROBLEM	POSSIBLE CAUSES	WHAT TO DO
<b>It is not cold enough inside the appliance.</b>	The temperature is set too high.	Set a lower temperature.
	Too warm goods has been stored.	Allow goods to cool prior to putting into the fridge.
	Too much food has been stored at one time.	Store food in small quantities.
	The goods are too close to each other.	Leave gaps between stored food to allow air flow.
	A door/drawer of the appliance is not tightly closed.	Close the door/drawer.
<b>It is too cold inside the appliance.</b>	The door/drawer has been opened too frequently or for too long.	Do not open the door/drawer too frequently.
	The temperature is set too low.	Set a higher temperature
<b>Moisture formation on the inside of the refrigerator compartment.</b>	The Super-Frz/Super-Coolfunction is activated or is running too long.	Switch off the Super-Frz/Super-Cool function
	The climate is too warm and toodamp.	Increase the temperature.
	A door/drawer of the appliance is not tightly closed.	Close the door/drawer.
	The door/drawer has been opened too frequently or for too long.	Do not open the door/drawer too frequently.
	Food containers or liquids are left open.	Let hot foods cool to room temperature and cover foods and liquids.
<b>Moisture accumulates on the refrigerator surface or between the doors/door and drawer.</b>	The climate is too warm and too damp.	This is normal in damp climate and will change when the humidity decreases.
	The door is not closed tightly. The cold air in the appliance and the warm air outside it condensates.	Ensure that the door/drawer is tightly shut.

## TROUBLESHOOTING



PROBLEM	POSSIBLE CAUSES	WHAT TO DO
<b>Ice and frost build-up in the freezer compartment.</b>	The goods were not adequately packaged .	Always pack the goods well.
	A door/drawer of the appliance is not tightly closed.	Close the door/drawer.
	The door/drawer has been opened too frequently or for too long.	Do not open the door/drawer too frequently.
	The door/drawer gasket is dirty, worn, cracked or mismatched.	Clean the door/drawer gasket or replace them.
<b>The sides of the cabinet and door strip get warm.</b>	Something on the inside prevents the door/drawer from closing properly.	Reposition the shelves, door racks, or internal containers to allow the door/drawer to close.
		This is normal.
<b>The appliance makes abnormal sounds.</b>	The appliance is not located on level ground.	Adjust the feet to level the appliance.
	The appliance touches some object around it.	Remove objects around the appliance.
<b>A slight sound is to be heard similar to that of flowing water.</b>		This is normal.

### Power interruption

In the event of a power cut, food should remain safely cold for about 5 hours. Follow these tips during a prolonged power interruption, especially in summer:

- ▶ Open the door/drawer as few times as possible.
- ▶ Do not put additional food into the appliance during a power interruption.
- ▶ If prior notice of a power interruption is given and the interruption duration is longer than 5 hours, make some ice and put it in a container in the top of the refrigerator compartment.
- ▶ An inspection of the goods is required immediately after the interruption.
- ▶ As temperature in the refrigerator will rise during a power interruption or other failure, the storage period and edible quality of food will be reduced. Any food that defrosts should be either consumed, or cooked and refrozen (where suitable) soon afterwards in order to prevent health risks.

## TECHNICAL DATA

Brand	Haier
Model name / identifier	HRF523XHG
Category of the model	Refrigerator-freezer
Energy efficiency class	4.5 STARS
Annual energy consumption(kWh/year)(1)	368
Total volume(L)	523
Volume refrigerator(L)	331
Volume freezer(L)	170 
Volume of two star(L)	22 
Temperature of other compartments>14°C	Non applicable
Frost-free system	Yes
Freezing capacity(kg/24h)	10
Climate rating(2)	T
Noise emission class and airborne acoustical noise emissions(db(A) re 1pW)	C(38)
Temperature rise time (h)	6
Type of appliance	freestanding

### Explanations:

(1) Based on the results of the standards conformance test over 24 hours. The actual consumption depends on the use and the location of the appliance.

(2) Climate rating SN: This appliance is intended for use in an ambient temperature of between + 10°C and +32°C

Climate rating N: This appliance is intended for use in an ambient temperature of between + 16°C and +32°C

Climate rating ST: This appliance is intended for use in an ambient temperature of between + 16°C and +38°C

Climate rating T: This appliance is intended for use in an ambient temperature of between + 16°C and +43°C

### Additional technical data

Voltage / Frequency	220-240V ~/ 50Hz
Input current (A)	1.8
Coolant	R600a
Dimensions (H/W/D in mm)	1775 / 908 / 647

# MANUFACTURER'S WARRANTY

---

Please read this warranty card carefully. Attach your purchase receipt to this warranty card and keep in a safe place. You must produce both warranty card and proof of purchase in the event of a warranty repair being required.

When you purchase any new Haier Product you automatically receive a two year Manufacturer's Warranty covering parts and labour for servicing.

## **The Manufacturer undertakes to:**

Repair or, at its option, replace without cost to the owner either for material or labour any part of the Product, the serial number of which appears on the Product, which is found to be defective within TWO YEARS from the date of purchase.

## **This warranty DOES NOT cover:**

- A Service calls which are not related to any defect in the Product. The cost of a service call will be charged if the problem is not found to be a Product related fault. For example:
  - 1 Correct the installation of the product.
  - 2 Provide Instruction on use of the product or change the setup of the product.
  - 3 Replace house fuses or correct house wiring.
  - 4 Correcting faults) caused by the user.
  - 5 Noise or vibration that is considered normal.
  - 6 Water on the floor due to incorrect loading or excessive suds.
  - 7 Blocked pumps, removal of foreign objects/substances from the machine, including the pump and inlet house filters.
  - 8 Correcting damage caused by pests, eg. rats, cockroaches etc.
  - 9 Correct corrosion or discolouration due to chemical attack.
  - !0 Power outages or surges.
- B Defects caused by factors other than:
  - 1 Normal domestic use or
  - 2 Use in accordance with the Product's User Guide.
- C Defects to the Product caused by accident, neglect, misuse or 'Act of God'.
- D The cost of repairs carried out by non-authorized repairers or the cost of correcting such unauthorised repairs.
- E Normal recommended maintenance as set out in the Product's User Guide.
- F Repairs when the appliance has been dismantled, repaired or serviced by other than an AUTHORISED CUSTOMER SERVICE CENTRE or the selling dealer.
- G Pick up and delivery.
- H Transportation or travelling costs involved in the repair when the product is installed outside the AUTHORISED CUSTOMER SERVICE CENTRE'S normal service area.

This product has been designed for use in a normal domestic environment. It is not intended for commercial use. Doing so may affect product warranty.

Service under this warranty must be provided by an Authorised Service Repairer (refer to the Customer Care section for contact details). Such service shall be provided during normal business hours. This warranty certificate should be shown when making any claim.

## MANUFACTURER'S WARRANTY

---

**Note:**

This Warranty is an extra benefit and does not affect your legal rights and applies only to product purchased in New Zealand and Australia. Please keep this Warranty Card in a safe place.

**For Australian customers:**

Our goods come with guarantees that cannot be excluded under the Australian Consumer Law. You are entitled to a replacement or refund for a major failure and for compensation for any other reasonably foreseeable loss or damage. You are also entitled to have the goods repaired or replaced if the goods fail to be of acceptable quality and the failure does not amount to a major failure.

## CUSTOMER SERVICE

---

We recommend our Haier Customer Service and the use of original spare parts.

If you have a problem with your appliance, please first check TROUBLESHOOTING. If you cannot find a solution there, please contact:

- Your local dealer
- The Service & Support area at **www.haier.com.au** or **www.haier.co.nz**

where you can activate the service claim and also find FAQs.

To contact our Service, ensure that you have the following data available.  
The information can be found on the rating plate at the door.

Model \_\_\_\_\_

Serial No. \_\_\_\_\_

### Complete and keep for safe reference:

Model \_\_\_\_\_

Serial No. \_\_\_\_\_

Purchase Date \_\_\_\_\_

Purchaser \_\_\_\_\_

Dealer \_\_\_\_\_

Suburb \_\_\_\_\_

Town \_\_\_\_\_

Country \_\_\_\_\_

# Haier

---

[WWW.HAIER.COM.AU](http://WWW.HAIER.COM.AU)  
[WWW.HAIER.CO.NZ](http://WWW.HAIER.CO.NZ)



0060543585